

MERKEL GUIDE BAND SF / KF

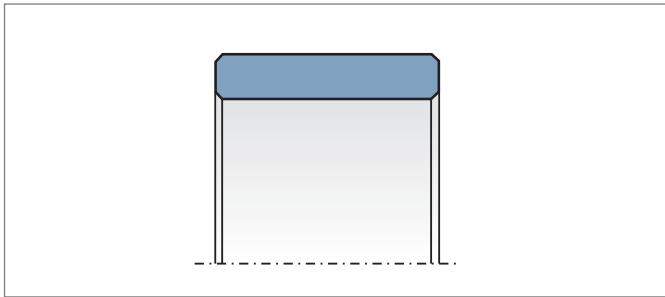

Merkel guide band SF (rod) resp. the version KF (piston) are non-metallic guide elements, either cut to size and ready for installation, or supplied as yard ware



VALUE TO THE CUSTOMER

- Low friction
- Stick-slip-free operation
- Suitable for standardized housings as per ISO 10766

Applications

Merkel Guide Band SF / KF can be used in all hydraulic fluids normally found in hydraulic systems such as oils and greases based on mineral oils, fire-resistant hydraulic fluids (HFD) and biodegradable hydraulic fluids (HETG, HEES, HEPG). We do not recommend to use guide bands SF in water or water based fluids (HFA, HFB, HFC). The maximum permissible operating temperature is 120 °C.

Material

Material	Designation	Color
PTFE-bronze compound	PTFE B500	brown



FEATURES AND BENEFITS

Surface finish

Peak-to-valley heights	R_a	R_{max}
Sliding surface	0,05 ... 0,3 μm	$\leq 2,5 \mu\text{m}$
Groove base	$\leq 1,6 \mu\text{m}$	$\leq 6,3 \mu\text{m}$
Groove sides	$\leq 3,0 \mu\text{m}$	$\leq 15,0 \mu\text{m}$

Material content $M_1 > 50\%$ to max. 90%, with cut depth $c = R_z/2$ and reference line $C_{ref} = 0\%$

Tolerances

Diameter D_1 / d_1	Profile thickness [mm]
H8 / h8	-0,05

The tolerance for dimensions d and D_f (SF) respectively D and d_1 (KF) must be viewed in connection with the seal used. Diameter D_1 (SF) respectively d_1 (KF) stated in the table of dimensions must be considered exclusively in conjunction with the guide band. The corresponding diameter of the connected seal housing has to be adapted to the sealing element involved.

L2 [mm]	Manufacturing tolerance [mm]
>20 ... 80	... 0,5
>80 ... 250	... 1,0
>250 ... 500	... 1,5
>500 ... 1.000	... 2,0
>1.000 ... 2.000	... 3,0
>2.000 ... 4.000	... 4,0

Surface load	Operating temperature
$p < 15 \text{ N/mm}^2$... 20 °C
$p < 7,5 \text{ N/mm}^2$... 80 °C
$p < 5 \text{ N/mm}^2$... 120 °C

Sliding speed, see sealing system.

Design notes

Please see the general design notes in our Technical Manual.

Cutting rolls to size

The dimensions indicated below are available as rolls ware from stock. Stretched length L2 of sections cut to size must be determined in line with the formula of calculation. Gap k arising after assembly is required for thermal expansion purposes. We recommend therefore that the guide bands are cut straight. Butt joint tips may be damaged by fissures. Our cutter (article No. 507228) makes it possible to cut sections to size in a time-saving and accurate manner.

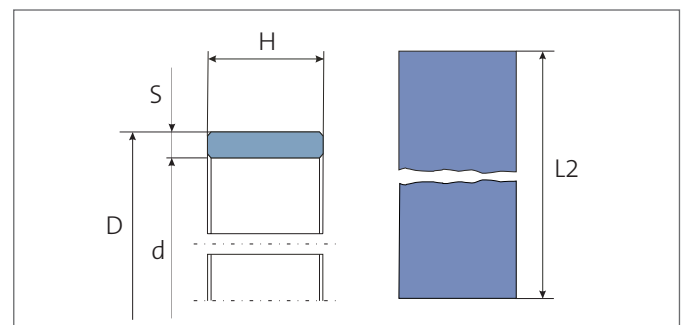

Calculating stretched length L2 for rods / pistons:
 $L2 = (D - S) \times 3,11 - 0,5$ / $L2 = (d + S) \times 3,11 - 0,5$

Groove length L [mm]	Band thickness S [mm]	Article No.
8	2,5	24226174
9,7	2,5	24102775
10	2,5	24102563
12	2,5	24099191
15	2,5	24102564
20	2,5	24076217
25	2,5	24107955
15	4	24160019
20	4	24238052
25	4	24148093



FEATURES AND BENEFITS

Surface force

Pressure within the contact area between the guide and the counter surface is not linear. The guiding width required can be calculated by applying the formulas mentioned below on the basis of

the projected area. The non-linear progression of the contact pressure process is taken into account in the surface pressure value. It may be advisable to reduce the loads by selecting a broader guide in individual cases to obtain an extended service life.

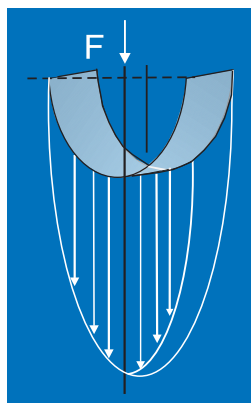

$$F_{\max} = P \times A$$

$$A = d \times H$$

$$H = F / (d \times P)$$

H = Width of guide band [mm]
 F = Radial loads [N]
 A = Projected area [mm²]

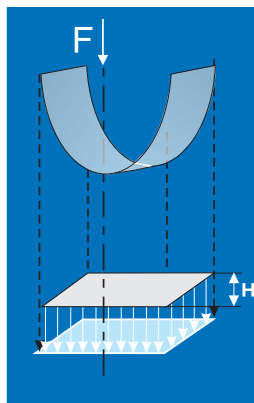

P = Permissible surface pressure [N/mm²]
 d = Rod diameter (rod guide) resp. piston diameter (piston guide) [mm]

Installation diagram

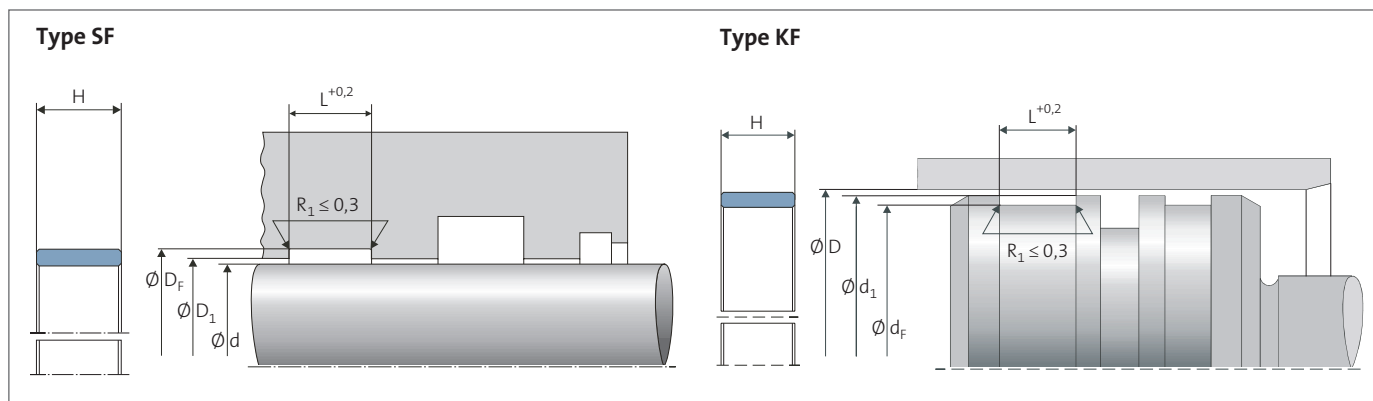

The information contained herein is believed to be reliable, but no representation, guarantees or warranties of any kind are made to its accuracy or suitability for any purpose. The information presented herein is based on laboratory testing and does not necessarily indicate end product performance. Full scale testing and end product performance are the responsibility of the user.

www.fst.com