

MERKEL DOUBLE WIPER PT1

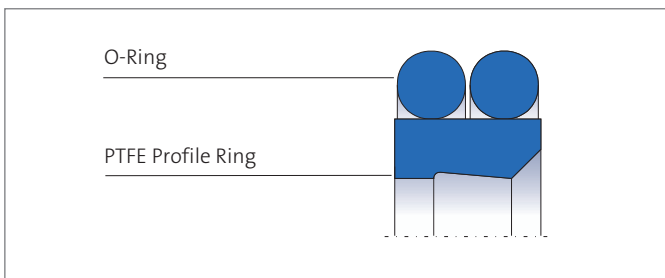

Merkel Double Wiper PT1, consisting of a PTFE profile ring with one sealing and one wiping edge, plus two O-rings as pre-stressing elements.



Applications

Double wiper with integrated sealing function for improving overall sealing capabilities. The PT 1 is preferably used in conjunction with our rod seals Merkel Omegat OMS-MR PR or U-Ring T20.

Material

PTFE Profile Ring

Material	Designation	Color
PTFE-glass-fibre - MOS2 compound	PTFE GM201	light gray
PTFE-bronze compound	PTFE B602	brown

O-Ring

Material	Designation
Nitrile rubber	NBR
Fluoro elastomer	FKM

Other material combinations are available on request.

VALUE TO THE CUSTOMER

- Enhanced functional reliability of the sealing system, due to additional sealing edge
- High operating reliability, due to sturdy profile ring made of PTFE compound (can briefly withstand the full operating pressure)
- Very good wiping capability for dirt adhering, due to dimensionally stable wiping edge
- Excellent control and positioning characteristics due to favorable frictional behavior (stick-slip-free)



TECHNICAL PROPERTIES

Operating Conditions

Material	PTFE GM201/NBR	PTFE B602/NBR	PTFE B602/FKM
Hydraulic oils, HL, HLP	-30 ... +100 °C	-30 ... +100 °C	-10 ... +200 °C
HFA fluids	+ 5 ... +60 °C	–	–
HFB fluids	+ 5 ... +60 °C	–	–
HFC fluids	-30 ... +60 °C	–	–
HFD fluids	–	–	-10 ... +200 °C
Water	+ 5 ... +100 °C	–	–
HETG (rape-seed oil)	-30 ... +80 °C	-30 ... +80 °C	-10 ... +80 °C
HEES (synth. ester)	-30 ... +80 °C	-30 ... +80 °C	-10 ... +100 °C
HEPG (glycol)	-30 ... +60 °C	-30 ... +60 °C	-10 ... +80 °C
Mineral greases	-30 ... +100 °C	-30 ... +100 °C	-10 ... +200 °C
Sliding speed	5 m/s	5 m/s	5 m/s

The figures given are maximum values and must not be applied simultaneously.

Surface Finish

Peak-to-valley heights	R_a	R_{max}
Sliding surface	0,05 ... 0,3 μm	$\leq 2,5 \mu\text{m}$
Groove base	$\leq 1,6 \mu\text{m}$	$\leq 6,3 \mu\text{m}$
Groove sides	$\leq 3,0 \mu\text{m}$	$\leq 15,0 \mu\text{m}$

Material content M_i > 50% to max. 90%, with cut depth $c = R_i/2$ and reference line $C_{ref} = 0\%$

The long-time behavior of a sealing element and its dependability against early failures are crucially influenced by the quality of the counter surface. A precise description and assessment of the surface is thus indispensable.

Based on recent findings, we recommend supplementing the above definition of surface finish for the sliding surface by the characteristics detailed in the table below. With these new characteristics derived from the material content, the hitherto merely general description of the material content is significantly improved, not least in regard to the abrasiveness of the surface. Please also consult our Technical Manual.

Surface finish of the sliding surfaces

Characteristic Value	Limit	
R_a	>0,05 μm	<0,30 μm
R_{max}	<2,5 μm	
R_{plx}	<0,5 μm	
R_{pk}	<0,5 μm	
R_k	>0,25 μm	<0,7 μm
R_{vk}	>0,2 μm	<0,65 μm
R_{vix}	>0,2 μm	<2,0 μm

The limit values listed in the table do not currently apply for ceramic or semi-ceramic counter surfaces. Please also consult our Technical Manual.

Tolerances

Diameter D	Tolerance
D	H9
D_1	H10

The tolerance for the diameter d is specified in connection with the gap dimension calculation for the primary seal. In typical hydraulic applications up to a nominal dimension of 1.000 mm, the tolerance fields f7 and f8 are usually chosen.

Design Notes

We recommend a pressure-relief bore. In the case of upstream seals with a good return capability, a pressure-relief feature is not necessary. Please also consult our Technical Manual.

Installation & Assembly

Reliable seal function is dependent on correct installation. Please also consult our Technical Manual.



GLAND DESIGN

Installation Diagram

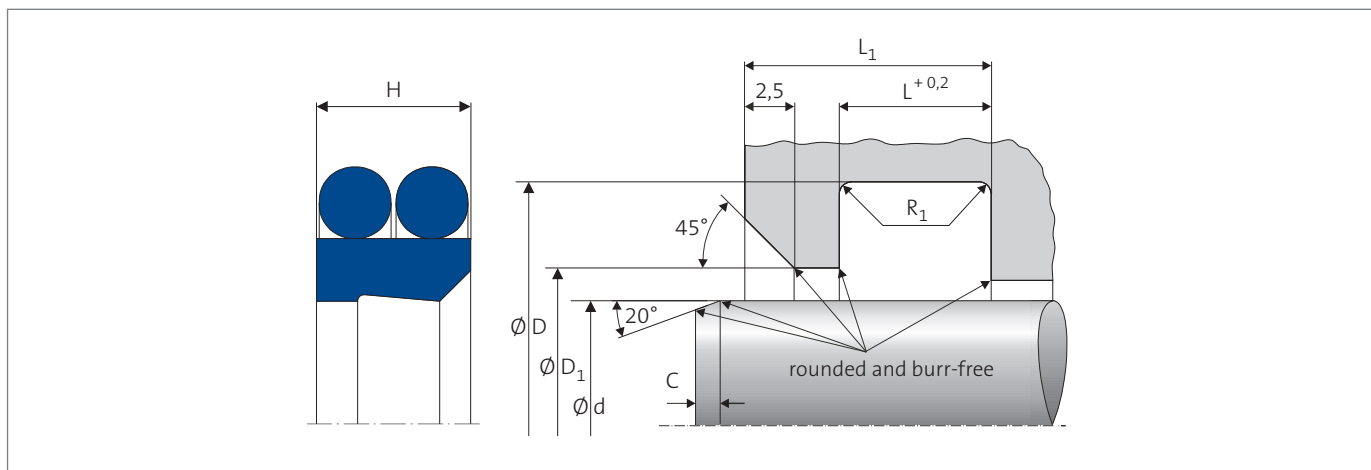

The information contained herein is believed to be reliable, but no representation, guarantees or warranties of any kind are made to its accuracy or suitability for any purpose. The information presented herein is based on laboratory testing and does not necessarily indicate end product performance. Full scale testing and end product performance are the responsibility of the user.

www.fst.com