

# MERKEL DOUBLE WIPER PT2

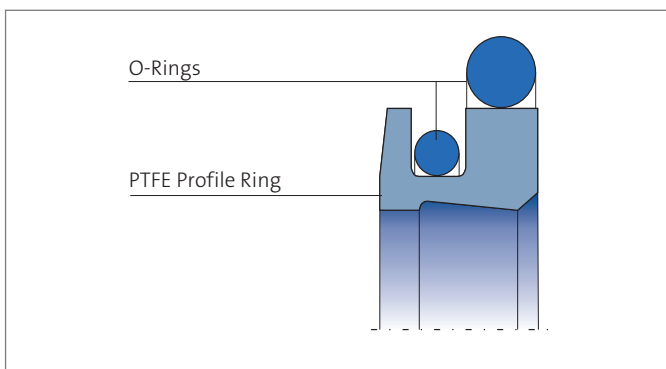

**Merkel Double Wiper PT2**, consisting of an engineered PTFE ring with one sealing edge and one wiper edge, plus two O-rings as energizers.



## VALUE TO THE CUSTOMER

- Excellent controllability and positionability during operation
- Low friction, stick-slip-free
- Material variants for short stroke and high frequency; available on request
- Particularly well suited for large diameters

### Applications

Double wiper with optimum wiping effect due to the support of the two O-rings. No build up of dirt due to closed gap.

The PT2 double wiper is principally used in conjunction with our Merkel Omegat OMS-S rod seals.

A pressure relief bore hole must be provided between the wiper and the downstream seal.

### Material

#### PTFE Profile Ring

Material	Designation	Color
PTFE-bronze compound	PTFE B602	brown
PTFE-glass-fiber-MoS2-compound	PTFE GM201	light gray

#### O-Ring

Material	Designation
Nitrile rubber	NBR
Fluoroelastomer	FKM

Other material combinations are available on request.



## FEATURES AND BENEFITS

### Operating Conditions

Material	PTFE GM201 / NBR	PTFE B602 / NBR	PTFE B602 / FKM
Hydraulic oils, HL, HLP	-30 ... +100 °C	-30 ... +100 °C	-10 ... +200 °C
HFA fluids	+ 5 ... +60 °C	-	-
HFB fluids	+ 5 ... +60 °C	-	-
HFC fluids	-30 ... +60 °C	-	-
HFD fluids	-	-	-10 ... +200 °C
Water	+ 5 ... +100 °C	-	-
HETG (rape-seed oil)	-30 ... +80 °C	-30 ... +80 °C	-10 ... +80 °C
HEES (synth. ester)	-30 ... +80 °C	-30 ... +80 °C	-10 ... +100 °C
HEPG (glycol)	-30 ... +60 °C	-30 ... +60 °C	-10 ... +80 °C
Mineral greases	-30 ... +100 °C	-30 ... +100 °C	-10 ... +200 °C
Sliding speed	5 m/s	5 m/s	5 m/s

The figures given are maximum values and must not be applied simultaneously.

### Surface Finish

Peak-to-valley heights	$R_a$	$R_{max}$
Sliding surface	0,05 ... 0,3 $\mu\text{m}$	$\leq 2,5 \mu\text{m}$
Groove base	$\leq 1,6 \mu\text{m}$	$\leq 6,3 \mu\text{m}$
Groove sides	$\leq 3,0 \mu\text{m}$	$\leq 15,0 \mu\text{m}$

Material content  $M_i$  > 50% to max. 90%, with cut depth  $c = R_i/2$  and reference line  $C_{ref} = 0\%$

The long-time behavior of a sealing element and its dependability against early failures are crucially influenced by the quality of the counterface. A precise description and assessment of the surface is thus indispensable.

Based on recent findings, we recommend supplementing the above definition of surface finish for the sliding surface by the characteristics detailed in the table below. With these new characteristics derived from the material content, the hitherto merely general description of the material content is significantly improved, not least in regard to the abrasiveness of the surface. Please also consult our technical manual.

### Surface finish of the sliding surfaces

Characteristic value	Limit	
$R_a$	>0,05 $\mu\text{m}$	<0,30 $\mu\text{m}$
$R_{max}$	<2,5 $\mu\text{m}$	
$R_{pkx}$	<0,5 $\mu\text{m}$	
$R_{pk}$	<0,5 $\mu\text{m}$	
$R_k$	>0,25 $\mu\text{m}$	<0,7 $\mu\text{m}$
$R_{vk}$	>0,2 $\mu\text{m}$	<0,65 $\mu\text{m}$
$R_{vtx}$	>0,2 $\mu\text{m}$	<2,0 $\mu\text{m}$

The limit values listed in the table do not currently apply for ceramic or semi-ceramic counterfaces.

Please also consult our technical manual.

### Tolerances

Diameter D	Tolerance
D	H8
$D_1$	H8

The tolerance for the diameter  $d$  is specified in connection with the gap dimension calculation for the primary seal.

In typical hydraulic applications up to a nominal dimension of 1.000 mm, the tolerance fields f7 and f8 are usually chosen.

### Design Notes

We recommend a pressure-relief bore. In the case of upstream seals with a good return capability, a pressure-relief feature is not necessary. Please also consult our technical manual.

### Installation & Assembly

Reliable seal function is dependent on correct installation. Please also consult our technical manual.



## FEATURES AND BENEFITS

### Installation Diagram

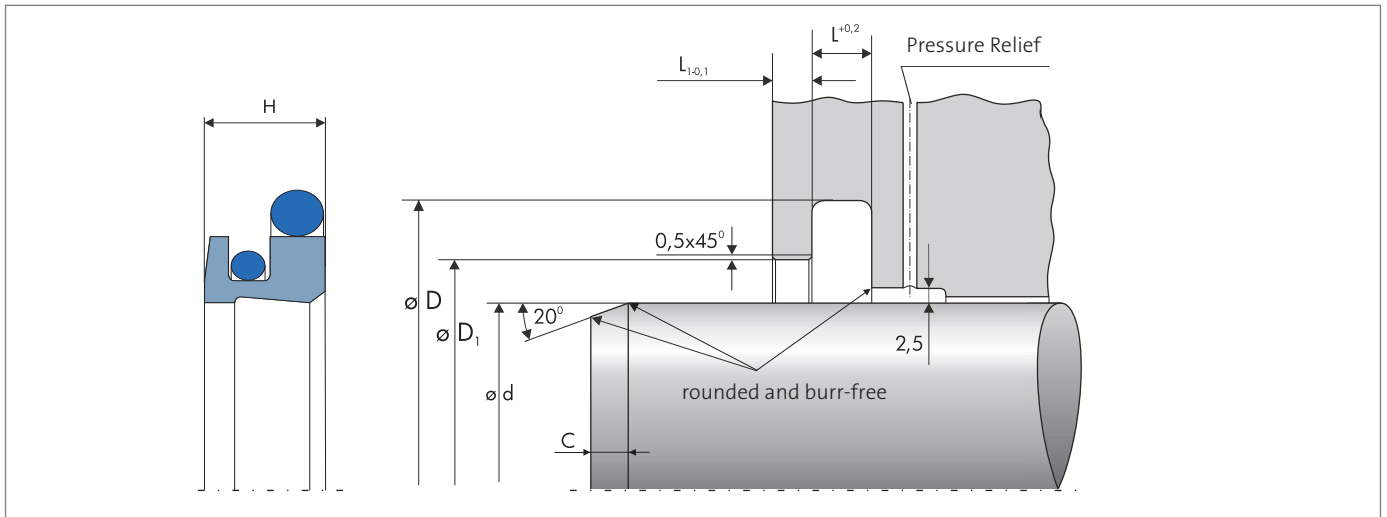

The information contained herein is believed to be reliable, but no representation, guarantees or warranties of any kind are made to its accuracy or suitability for any purpose. The information presented herein is based on laboratory testing and does not necessarily indicate end product performance. Full scale testing and end product performance are the responsibility of the user.

[www.fst.com](http://www.fst.com)