

DICHTOMATIK

V-ring seal VA

DESCRIPTION

- Standard design
- Stiffening body, joint and sealing lip
- Material: NBR, FKM

FUNCTION

- Sealing against dust, dirt, grease, oil or water splashes
- Protects radial shaft seals or bearings from abrasive ambient conditions as a primary sealing element (lip seal or flinger ring)
- Good for use in combination with rotary shaft seals

PRODUCT ADVANTAGES

- Good dynamic sealing effect
- Compensation of small axial movements as well as angular and radial misalignments
- Low requirements on surface quality of the mating surface
- Friction decreases with increasing peripheral speed
- Reliable design with broad application spectrum for moderately demanding applications in general industry
- Good price/performance ratio
- Manufactured by certified external suppliers

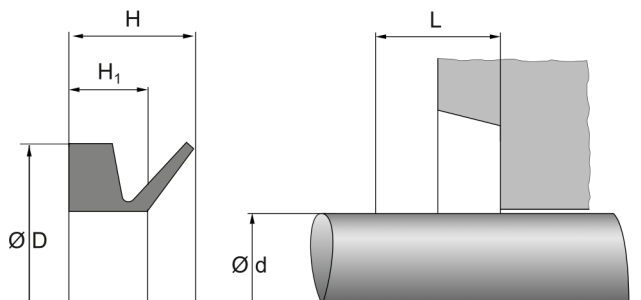

APPLICATIONS

- General mechanical engineering
- Plant engineering
- Drive technology
- Electric motors
- Gearboxes
- Agricultural machinery
- Rolling mills
- Bearing pedestal seal

APPLICATION LIMITS

- Pressure [Mpa]: max. 0
- The values given here are maximum values and may not all be reached at the same time.

NBR

- Temperature [°C]: -40 to 100
- Peripheral speed [m/s]: max. 8
- For circumferential speeds ≥ 8 m/s, axial securing is required, for ≥ 12 m/s additional radial securing is required

FKM

- Temperature [°C]: -25 to 200
- Peripheral speed [m/s]: max. 6,5
- At circumferential speed ≥ 6.5 m/s, axial securing is required, at ≥ 10 m/s radial securing is also required

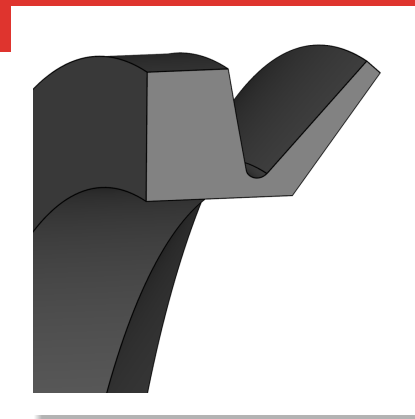

DICHTOMATIK

V-ring seal VA

MEDIA RESISTANCE

NBR

- Good chemical resistance to various mineral oils and greases (H, HL, HLP)
- Flame-retardant hydraulic fluids HFA and HFB, HFC up to appr. +50°C
- Water up to max. +60°C
- Low resistance to ozone, weathering and ageing

FKM

- Good chemical resistance to mineral oils and greases, synthetic oils and greases, engine, gearbox and ATF oils up to approx. +150 °C
- Fuels, flame-retardant pressure fluids HFD, aliphatic, aromatic and chlorinated hydrocarbons
- Water up to max. +60°C
- Very good resistance to ozone, weathering and ageing

CONFORMITY AND CERTIFICATES

- Please consult the material data sheet valid for the respective material for current information on approvals and certificates, as this information depends on the compound and cannot be listed exhaustively here.

DESIGN GUIDELINE

- Shaft surface roughness $R_z = 1.0$ to $4.0 \mu\text{m}$
- No surface shape deviations or defects such as sharp edges, burrs, blowholes, waviness, elevations or damage permitted
- Chamfer on shaft 10-20°, polished transition
- Mating surface should be at right angles to the shaft
- Counterface surface roughness $R_a \leq 2 \mu\text{m}$
- Hardness of mating surface depends on the material and medium: Construction steel and sludge: 125 - 150 HV | Grey cast iron and sludge, dust: 190 - 270 HV | Cast bronze and water, dust: 100 - 160 HV | Cast aluminum and splash water: 90 - 160 HV | Stainless steel and water: 150 - 200 HV
- Shaft tolerance zone: ISO h11

INSTALLATION GUIDELINE

- Deburr sharp edges, provide with seamless chamfers and radii
- V-ring can be temporarily expanded by up to 20% for installation

STORAGE ADVISE

- Storage temperature $< 25^\circ\text{C}$
- No direct heat sources
- No direct sunlight
- No condensation in the storage room
- No exposure to ozone or ionizing radiation
- Recommendations based on the revision of ISO 2230 dated 16.09.1992

The information contained herein is believed to be reliable, but no representations, warranties or guarantees of any kind are made as to its accuracy or suitability for any purpose. The information reproduced herein is based on laboratory testing and is not necessarily indicative of end product performance. Complete testing and performance of the end product is the responsibility of the user.

© Freudenberg FST GmbH | dichtomatik.fst.com